

# 3. Freigericht Classic

**Aufgabe 7**

**Punkte**

S
T



Copyright 2015 Freigericht e.V. / OSM contributors / OpenStreetMap contributors (CC BY-SA 2.0) / GFDL

**Aufgabe 8**

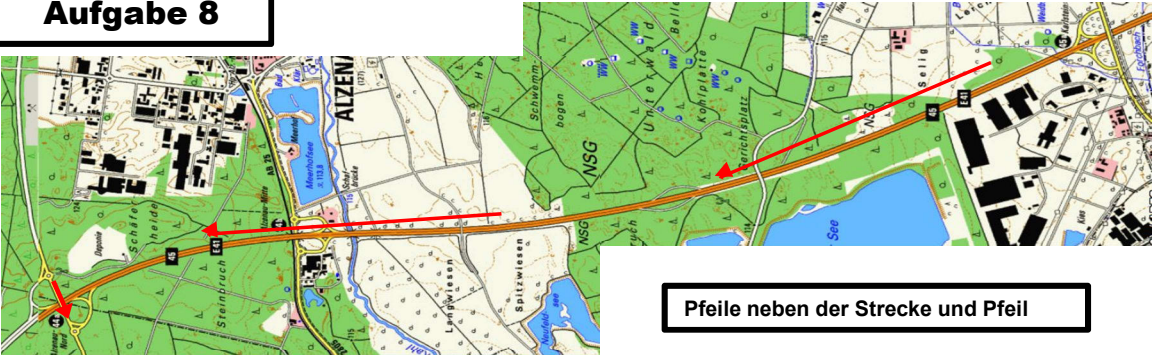

Pfeile neben der Strecke und Pfeil







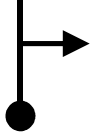
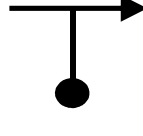
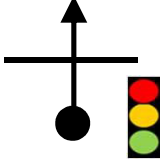

<p>2,1 km</p>	<p>3,8 km</p>	<p>5,8 km</p>
---------------	---------------	---------------

<p>6,15 km</p>	<p>2,3 km</p>
----------------	---------------

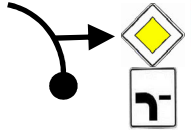
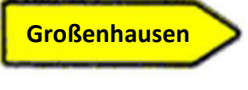
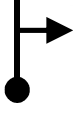
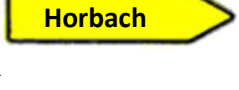
<p>700 m</p>	<p>220 m</p>	<p><b>Ziel</b> 1. Etappe</p> <p>130m</p>
--------------	--------------	--

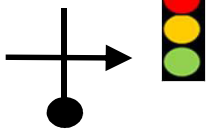
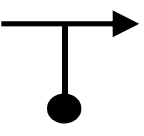
<div style="border: 1px solid black; padding: 5px; background-color: yellow;"> <b>Essen</b> fassen         </div>		<p><b>Mittagspause</b></p>
---	---	----------------------------

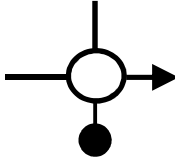
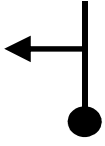
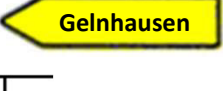
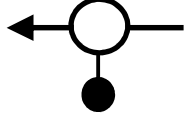
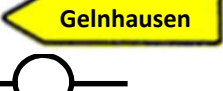
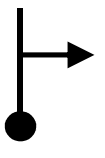
# 3. Freigericht Classic

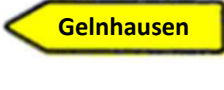
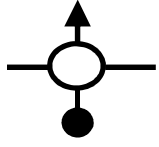
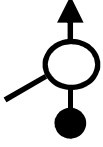
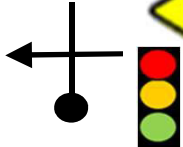
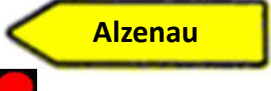
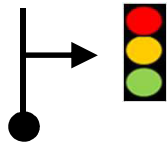
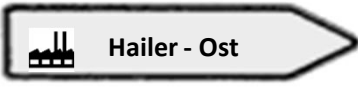
<p><b>Start</b> 2. Etappe</p>		 100 m	 550 m
 180 m		 1,6 km	 2,4 km
	 800 m		 1,2 km
 2,15 km	 5,4 km		 550 m
 430 m	<p>Fahren Sie die K 894 über Eidengesäß nach Breitenborn und dann weiter in Richtung Lanzingen.</p>		
 140 m		 5,4 km	
	 650 m	 4,7 km	 1,15 km
	 1,6 km		 1,9 km